

## “AKKU 4 LIFE” – Eksperimentalna diagnostika stanja rabljenih litij-ionskih baterij

STEPHAN THALER, CHRISTOPH URAN & MARTIN PECNIK

**Povzetek** Z namenom omogočiti ponovno uporabo rabljenih baterij je potrebna zanesljiva ocena njihovega stanja. Za predselekcijo v procesu recikliranja je potrebna hitra in smiselna analiza stanja. Ta predselekcija mora potekati preko elektronskih sistemov za analizo, pa naj bo govora o popolnem uničenju, spremembi, obnovi ali je potrebno ponovno polnjenje in »osvežitev«. Osnova za vključitev merilnega sistema bo v tem projektu potekala pod naslovom »Dinamični Analizator Baterij«.

**Ključne besede:** • diagnostika • rabljene baterije • litij-ion • merilni sistem • analiza baterij •

---

NASLOV AVTORJEV: mag. Stephan Thaler, Univerza v Beljaku, Europastrasse 4, A-9524 Beljak, Avstria, e-pošta: thaler@cuas.at. Christoph Uran, Univerza v Beljaku, Europastrasse 4, A-9524 Beljak, Avstria. Martin Pecnik, Univerza v Beljaku, Europastrasse 4, A-9524 Beljak, Avstria.

<https://doi.org/10.18690/978-961-286-071-4.13>

ISBN 978-961-286-071-4

© 2017 Univerzitetna založba Univerze v Mariboru

Dostopno na: <http://press.um.si>.

## “AKKU 4 LIFE” - An Experimental Health Condition Diagnosis of Second-Life Lithium-Ion Batteries

STEPHAN THALER, CHRISTOPH URAN & MARTIN PECNIK

**Abstract** In order to enable the reuse of a second hand battery a reliable assessment of their health status is necessary. For preselection in the recycling route very quick and meaningful status analyzes are required. This preselection whether total loss, alteration, rebuilding or reloading and ”Refreshing” is necessary, and is to take place via electronic analysis systems. The basis for this measurement system integration is to take place under the Device title ”Dynamic Battery Analyzer DBA” in this project.

**Keywords:** • diagnosis • second hand batteries • Lithium-Ion • measurement system • battery analyzer •

---

CORRESPONDENCE ADDRESS: Stephan Thaler, M.S., Carinthia University of Applied Sciences, Europastrasse 4, A-9524 Villach, Austria, e-mail: thaler@cuas.at. Christoph Uran, Carinthia University of Applied Sciences, Europastrasse 4, A-9524 Villach, Austria. Martin Pecnik, Carinthia University of Applied Sciences, Europastrasse 4, A-9524 Villach, Austria.

<https://doi.org/10.18690/978-961-286-071-4.13>

ISBN 978-961-286-071-4

© 2017 University of Maribor Press

Available at: <http://press.um.si>.

## 1 Introduction

Secondary battery cells, that do not fulfill their function anymore will be deposited or discarded nowadays. Recycling the resources gained from these batteries is the method of choice today. But with the rising amount of mobile devices and electric cars on the market also a higher amount of batteries is discarded although they are still in a condition where they could be used in so called Second Life Applications (e.g. storage stacks at photovoltaic systems). Before these cells can be used in other applications a state diagnosis has to be done to guarantee a defined state of the battery. For this interpretation the State of Health (SOH) is used. The SOH in this case is defined by the quotient of the actual battery capacity divided by the nominal capacity. The nominal capacity can be found

in the specific datasheet of the battery tested [Panasonic 2012]. Since the background of the project, the experimental classification method, is not only a scientific but also economic, other parameters have to be taken into account as well. Therefore, the goal is to analyze just the first ten seconds of the discharging behavior of a fully charged battery. To perform this measurement, special electronics as well as statistical methods are needed to calculate a representative result to the user of

the system. Only a fast as well as precise algorithm will allow the usage of this system in an industrial environment. In the following sections, the different sub-systems as well as the algorithm needed to perform this result will be described.

## 2 Approach

As already mentioned in the introduction, the goal is to develop a method to classify secondary lithium-ion batteries. This method is then planned to be implemented on a measurement device that will allow a user to perform a cell classification without having any special knowledge about measurement techniques. To be able to fulfill this goal a general system structure was established at the beginning of the development phase. This structure consists out of three main parts to be developed that can be seen in figure 13.1.

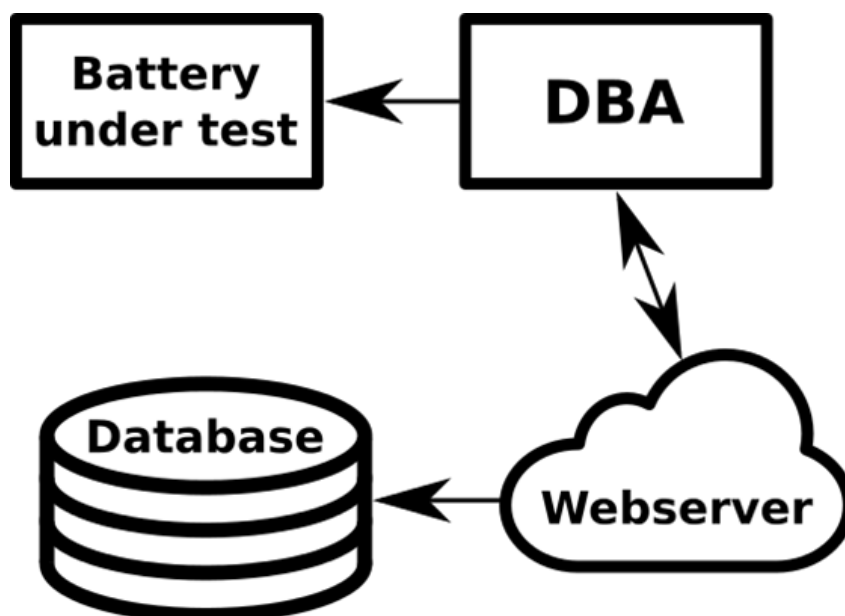

Fig. 13.1. Overall system structure

The Dynamic Battery Analyzer (DBA) is the connection between the user and the measurement system. A battery to be analyzed (which is the battery under test in figure 1) is plugged into the device and when the user presses the start button the measurement is done automatically. The cell characterization itself does not take place on the DBA to save resources. Instead, it is executed on the web-server. The communication between the DBA and the server takes place over the Internet, to which the DBA is connected via a pre-defined WiFi network. This web-server then compares the measured values with reference values which are stored in a database. This modular system structure is more complex to develop because of the different platforms to develop on but will also allow a maximum amount of flexibility and performance for more complex algorithms. The classification method is a curve comparison algorithm between reference data and measured data. The former will be stored in a database on the web-server while the latter is coming from the DBA. To gain the reference data, precharacterization measurements are performed in a laboratory environment. These measurements are executed on a special test stand that allows to charge and discharge batteries with defined C-rates and temperatures. These measurements allow us to analyze the capacity decrease of a secondary battery and therefore its voltage behavior when a load is applied. Since the discharge behavior varies depending on temperature, load, SOH of the cell and other factors, three distinctive temperatures as well as one discharge load was chosen for every supported battery type.

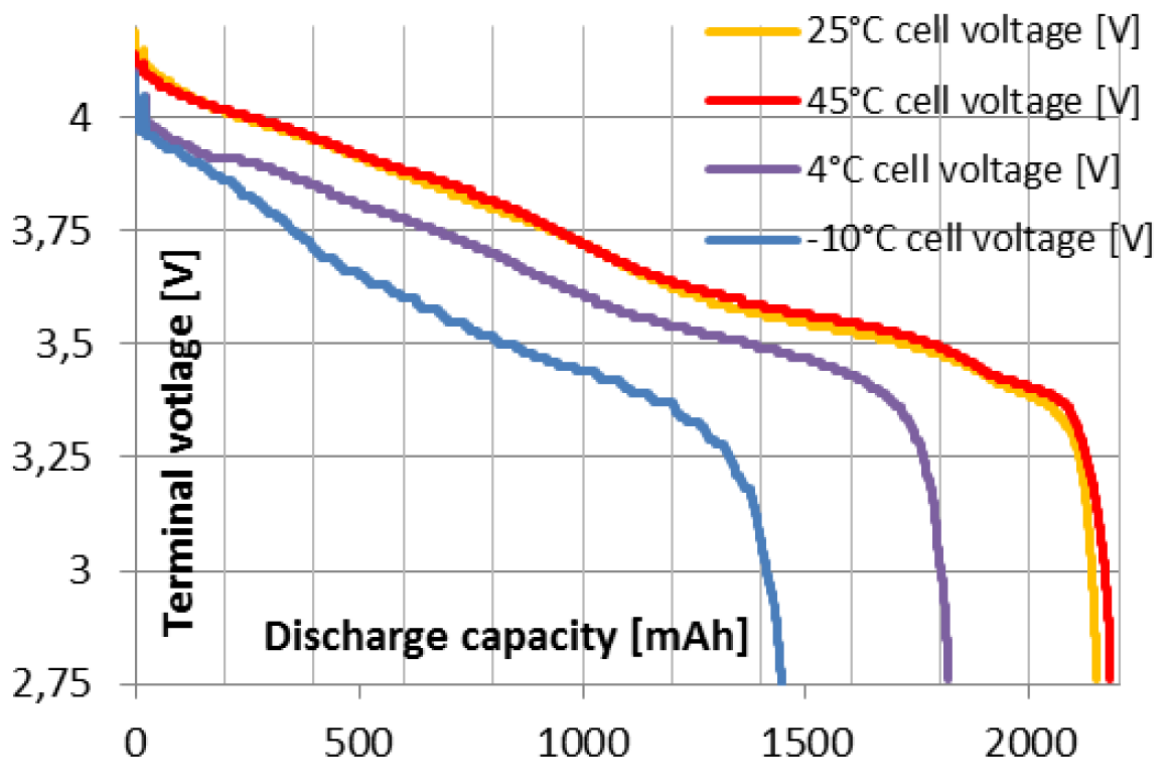

Fig. 13.2. Capacity variation through different temperatures [Elbe 2014]

### 3 Methodology

This section gives a more detailed description of the subcategories mentioned in the previous section.

### 3.1 Battery Aging

The battery aging is performed on special test bench which was developed within the project Akku4Future at the Carinthia University of Applied Sciences [Elbe 2014]. One of the outcomes of this project was that there are certain temperatures where batteries have highly different discharge behavior though the same load is applied (see figure 13.2).

Therefore, three significant temperatures were chosen for the battery aging process: 0\_C, 25\_C and 45\_C. The batteries to be analyzed are from Panasonic [Panasonic 2012], Samsung and Sony [BMZ 2011]. For batteries used in the industry, most of the times there is no charge and discharge history available which provides information about the condition of the battery. Therefore, the load applied on the batteries under test is assumed to be the maximum load specified in the datasheet. Only batteries that are in an overall good condition, which means that they can be reused, allow such high load without a too high initial voltage drop or even breakdown.

### 3.2 Data Analysis and Preparation

Before saving the data from the test bench in the database the different curves have to be standardized to later guarantee the usage of one mathematical function for all different battery types realized. The results from the test bench are voltage curves that describe the charge and discharge behavior. Using the discharging currents over the time it is possible to recalculate how much capacity is drawn out of a battery. This discharge cycle will describe the battery's SOH as described in the following equation.

$$SOH = \frac{C_{meas}}{C_{nom}} \quad (1)$$

$C_{meas}$  in this case describes the calculated capacity through the measured current over time relation and  $C_{nom}$  is the nominal capacity that can be found in the datasheet of a battery. With the help of this discharge data a classification can be done. For this purpose, curves with SOH steps of 5% were used to later on represent a certain discharge behavior depending on the SOH of a battery.

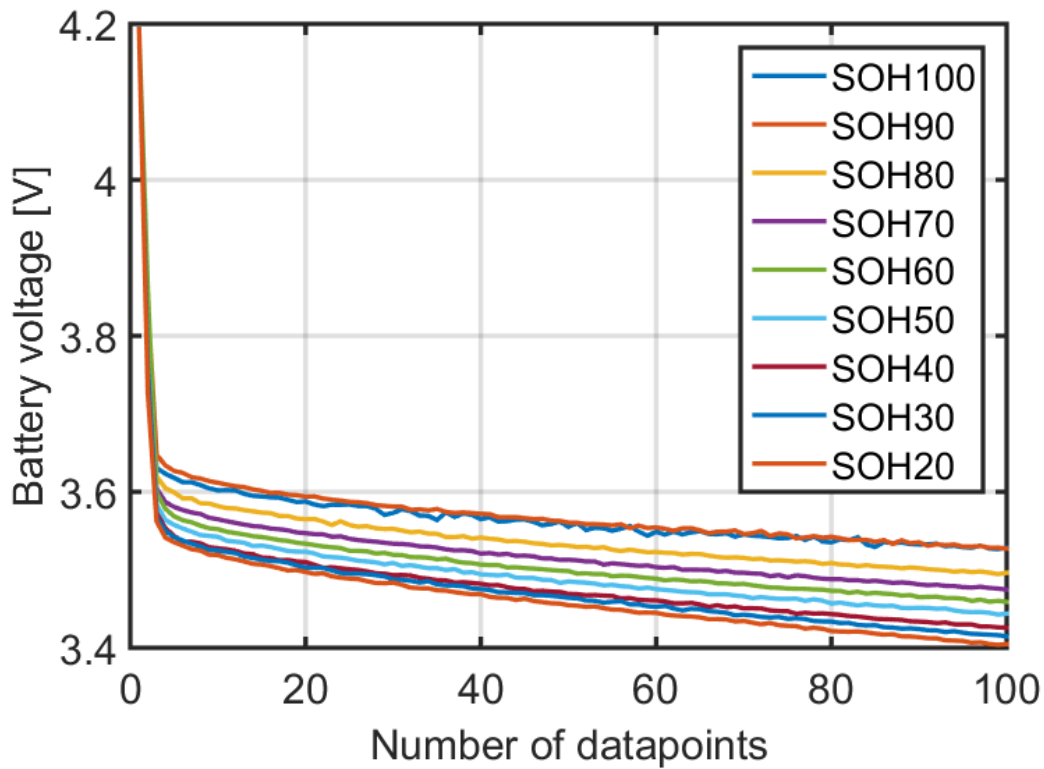

Fig. 13.3. Classification curves representing different SOH values

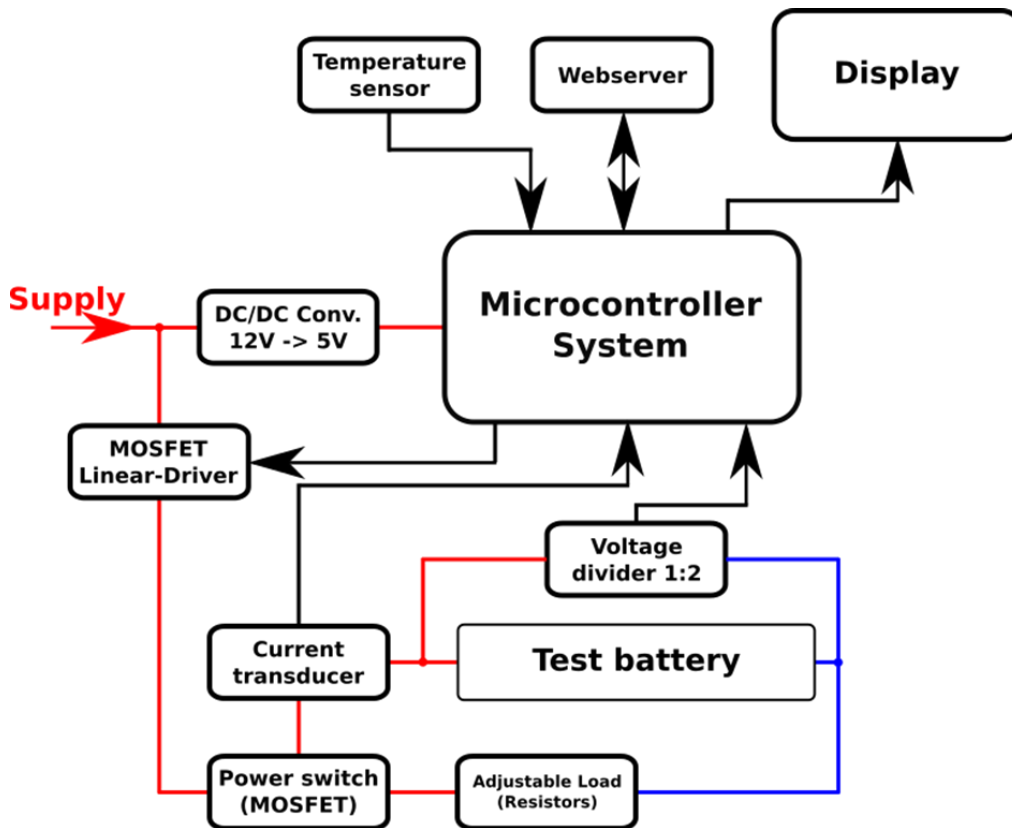

Fig. 13.4. Systematic structure of the Dynamic Battery Analyzer

After the classification and labeling of the discharge curves they can finally be prepared for the database. Since it was already mentioned in the introduction the goal is to characterize the unknown battery cells with a ten second maximum current discharge. Also the labeled reference dataset, that show the complete discharge of the cell, have to be prepared for this purpose. To minimize the storage needed for the database only the first 1000 values from the discharge curves are stored. They were measured at a frequency of 100Hz and therefore represent the first ten seconds of discharge. Finally, 20 reference curves (similar to the ones seen in figure 13.3) will be stored in the database to later on represent a certain SOH. The method that will be used for this comparison will be described in the section IV.

### 3.3 Dynamic Battery Analyzer

The DBA is a device that helps to indicate the SOH of an unknown battery cell using a newly developed experimental classification method. In this case, unknown battery means that neither the charging or discharging history of the cell nor the temperatures the battery was used at are known. The task of the DBA is to provide a user interface, where a user is able to select the type of battery to be measured, enter a battery identification number and start the characterization after inserting a fully charged battery into the device. The system structure of the DBA can be seen in figure 4. The complete system will be supplied by a 230VAC to 12VDC ACDC converter. The 12VDC level was chosen to provide an amplitude that is high enough to drive elements like operational amplifiers without having any additional boost converters. For the supply of the micro-controller system a linear voltage regulator is used that will provide 5VDC at the output. The micro-controller system itself consists of a Raspberry Pi1 communicating via I2C2 with an Arduino Uno3. The Raspberry Pi in this case works as the main controller, displays the user interface, allows the input via a touch display, coordinates the I2C data transmission to the Arduino Uno and finally also performs the communication with the web-server via WiFi. The Arduino Uno was chosen for the measurement task because it is an inexpensive platform that is well documented on the web. The task of the Arduino is to discharge the battery under test with a constant current, measure the terminal voltage and later on send these voltage values back to the Raspberry Pi via I2C. Since the I2C bus only allows to send values of size 'Byte' and the voltage is stored as millivolts, the only way to send one voltage value is to split it up to four single characters on the Arduino and send them to the Raspberry Pi sequentially, where they are pieced back together after the transmission has finished. Since this procedure takes a lot of time, the complete measurement is first performed on the Arduino, where all the voltage values are stored in an array. After finishing the measurement the complete array is sent to the Raspberry Pi at once with the method described before. Also the temperature is of high importance as it was already mentioned in section 3.1. Therefore an ambient temperature measurement is performed before the actual battery discharge to later on decide, which SOH reference curves have to be used. The battery discharge circuit consists of four main elements. The first is the battery itself that will only close the circuit if inserted into the battery tray. For the discharging process itself, a MOSFET is used, where the gate is not controlled via a PWM signal coming from a MOSFET driver, but an analogue voltage provided by an operational amplifier circuit. This has the big advantage that the current signal seen by the current transducer is also an analogue signal and can directly be used without using any average calculations. The current transducer was chosen to work on Hall effect because of the high discharge currents of up to 30A. The disadvantage of this MOSFET control method is that there is a lot of heatloss since the drain-source path is not opened completely. Therefore a high-ohmic load resistor has been used between the MOSFET and the battery to lower the voltage drop across the MOSFET and consequently also decrease

the losses produced. To support the heat conduction, a separate heat sink is attached to the MOSFET. The most important information is the voltage behavior of the battery that will directly be measured via a voltage divider based on resistors. The voltage divider is only used for protection since the maximum input voltage for the analogue input of the Arduino Uno is 5VDC. The measurement frequency for the voltage will be 100Hz. The current has to be controlled with a much higher frequency since the quality of the measurement is depending on how exact the discharge current can be held depending on the specification from the data sheet. The currents for every single battery type will not be saved on the Arduino but initially sent via I2C from the Raspberry Pi. Therefore the only logic functions working on the Arduino are the current measurement and the data logging. The voltage data is then transferred to the Raspberry Pi and afterwards sent to the web server via WiFi as described in the next section.

### 3.4 Server and Database

As already mentioned in the previous sections, the data produced by the DBA is sent to the server via the Internet. However, the communication mechanism has not yet been explained. Basically, it works via a RESTful web service [Richardson/Ruby 2008] provided by the server. The reason for using the REST (Representational State Transfer) paradigm is that the provided and requested data is stateless, i.e. immediately successive measurements by a single DBA are not related in any way. Furthermore, using REST has the advantage that one can use simple and well-defined HTTP (Hyper Text Transfer Protocol) requests such as GET (retrieving information), POST (sending information), PUT (updating information) and DELETE (deleting information) as defined in RFC 2616 [Berners-Lee et al. 1999]. Also status codes of the responses are defined in the RFC, e.g. status code 200 for OK or 201 for Created. All of this makes the communication much more standardized and easier to handle on both the DBA and the server. For transmitting the desired data, we use JSON (JavaScript Object Notation). This enables us to remain very flexible in terms of how the transmitted data is structured. The server in its current form provides two so-called REST endpoints:

**Check:** This endpoint checks if the connection to the server can be established by the DBA. After a GET request is received by this endpoint, it either returns a response with the status code 204 (for No Content) if the server is reachable and can be used or a response with the status code 500 (for Internal Server Error) if the server encountered problems.

**Soh:** This endpoint has two purposes. The first purpose is to return the SOH according to the given measurement values. When receiving a POST request with a correctly formatted JSON string it returns a response with the status code 200 (for OK) and the calculated SOH for the given measurement values. Furthermore, it stores the request for later analysis. If the server encounters a problem, it returns a response with the status code 500. The second purpose is to display the last measurements in human readable form. When receiving a GET request on this endpoint the server returns a response with the status code 200 and an HTML (Hyper Text Markup Language) representation of the last measurements in a table. The following listing shows an example for a JSON formatted request onto the soh endpoint to get the SOH according to the given measurement values.



```
{
  "deviceId": "123 abc",
  "type": "Battery1",
  "temp": 25.2,
  "voltages": [3.5, 3.4, 3.2, ...]}

```

For finding the set of reference values that best matches the measured values we have chosen to use the NRMSE (Normalized Root Means Squared Error), which is shown in equation 2. All of the logic explained above has been implemented in Java and Apache Jersey4 has been used as a REST framework. In addition to the server software also an efficient database structure was needed. The created structure can be seen in figure 13.5. Due to the table reference type the system is very modular in terms of which kind of measurement data can be processed. If at any point it is desired to measure the amperage or the wattage instead of or in addition to the voltage, this can be easily achieved with this structure. Furthermore it is possible to handle any amount of battery types and measurement temperatures as well as any resolution for the SOH.

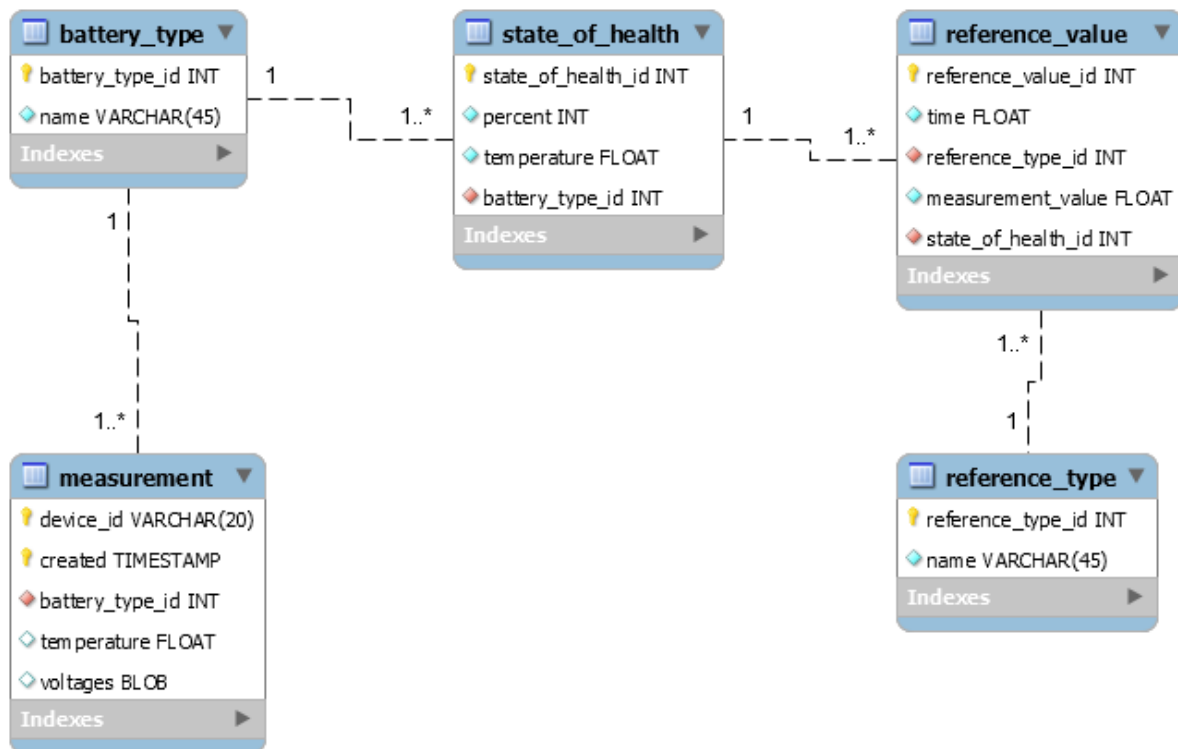

Fig. 13.5. Structure of the database for measurement and reference data

#### 4 Results

In this section, the results of the comparison algorithm using measured data coming from the test bench can be seen. For this purpose a statistical method based on the chi-squared test goodness of fit method was used [Peck/Devore 2012]. This function was then normalized to gain a result as it can be seen in equation 2. It can also be found in the Matlab 'goodnessoffit' function 5 in a similar way. The implementation will lead to a slightly different result since the Matlab function will use 1 as a perfect fit and the equation 2 will directly show the error, so 0 would indicate no error.

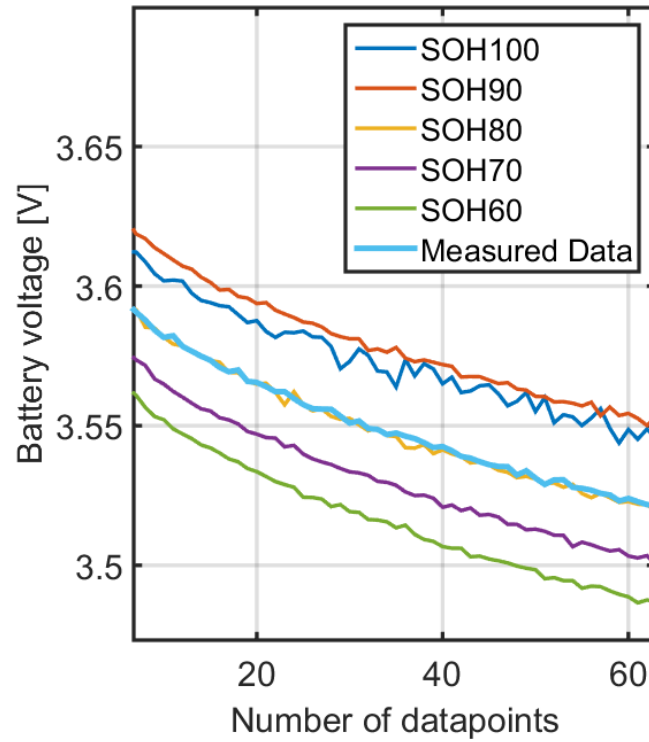

Fig. 13.6. Comparison of measured and reference data

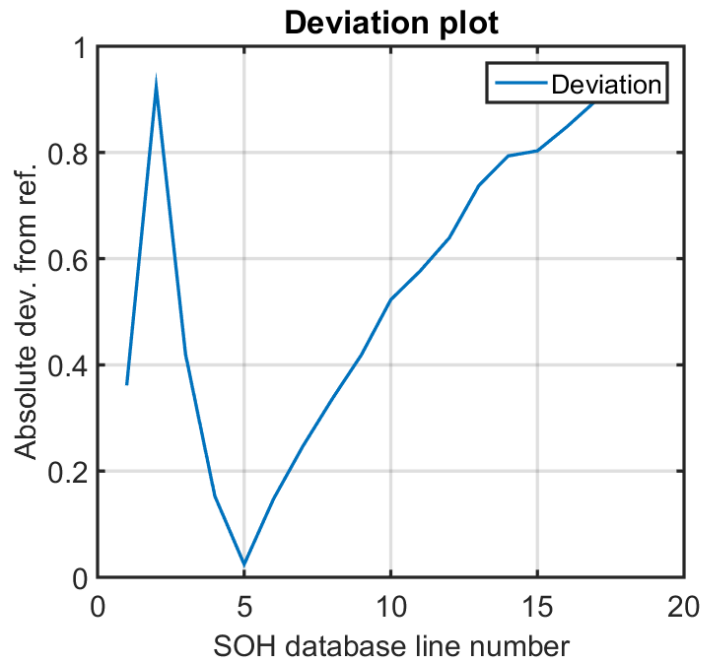

Fig. 13.7. Deviation between measured and reference data

$$NRMSE = \frac{\sqrt{\frac{\sum_{i=1}^n (X_{obs,i} - X_{model,i})^2}{n}}}{X_{obs,max} - X_{obs,min}}$$

(2)

Since the algorithms running on the server do not have a direct graphical user interface, the reference data from the database and measured data from the test bench were used in a Matlab script with to visualize the results. Equation 2 was used in Matlab to make the comparison between measured and reference data. For the measured values, data from the controlled battery aging process were used because they are already characterized and therefore will also show if the method used for comparison is whether right or wrong. The data used for the comparison can already be seen in figure 13.3. When zoomed in, the a more clear result can be seen as shown in figure 13.6. For this test a measured curve very similar to the reference curve was chosen because it shall show that there are huge differences in the deviation compared to other reference curves (see figure 13.7). This deviation, the result of the NRMSE algorithm, will be stored in an array. Finally the array entry with the lowest deviation will show the SOH of the battery tested. In the server, this value will then be passed on to the Raspberry Pi to be shown to the user.

## 5 Conclusion

The aim of this project is to develop a method to classify secondary lithium-ion batteries. This was achieved with a measurement device which includes the user interface, the battery measuring point, and the connection to the web server where the comparison of the measured values with the stored values takes place. As one will directly notice, the results published in this paper are from an ongoing project and document its state at the end of February 2016. The section "Results" shows that the methods used for the indication are plausible and will work as long as the measured data coming from the DBA is accurate enough that there will not be too high ripples. The server and database system implemented work fine in combination with the Raspberry Pi and using I2C bus for the communication between Raspberry Pi and Arduino also shows good results when sending single characters. The future goal of this project will be the implementation and test of all sub-functions within in one system. Since all single systems can already run nonindependent the most important work will have to be invested in the improvement of the current measurement at the DBA and the NRMSE method running on the web-server.

## References

- [1] A.Elbe, Akku4Future-Measurement methods for lithium-ion battery systems, Villach, AV Akademikerverlag, 2014
- [2] BMZ, BM18650Z3 Lithium Ion Manganese Cell - datasheet, Rev.1.0, 19.12.2011
- [3] L. Richardson and S.Ruby, RESTful Web Services. O'Reilly Media, 2008
- [4] Panasonic Energy Company, Panasonic Lithium Ion NCR18650 - datasheet, Version 13.11 R1, 2012
- [5] Peck R., Devore J., Statistic: the exploration and analysis of data - 7<sup>th</sup> edition, Belmont, CA, [6]Brooks/Cole Cengage Learning, 2012, ISBN 978- 0-8400-6859-0
- [7] T. Berners-Lee et al. (1999). Hypertext Transfer Protocol – HTTP/1.1, RFC 2616 [Online].

